

# ASTON<sup>®</sup>

**YOUR COMPLETE GO-TO MACHINE**

**ATC-1600 Smart Solution**  
TIRE EQUIPMENT SPECIALIST



**Aston Technologies, Inc.**  
**[www.astontechusa.com](http://www.astontechusa.com)**



## ATC-1600 OVERALL DIMENSIONS

# ASTON®

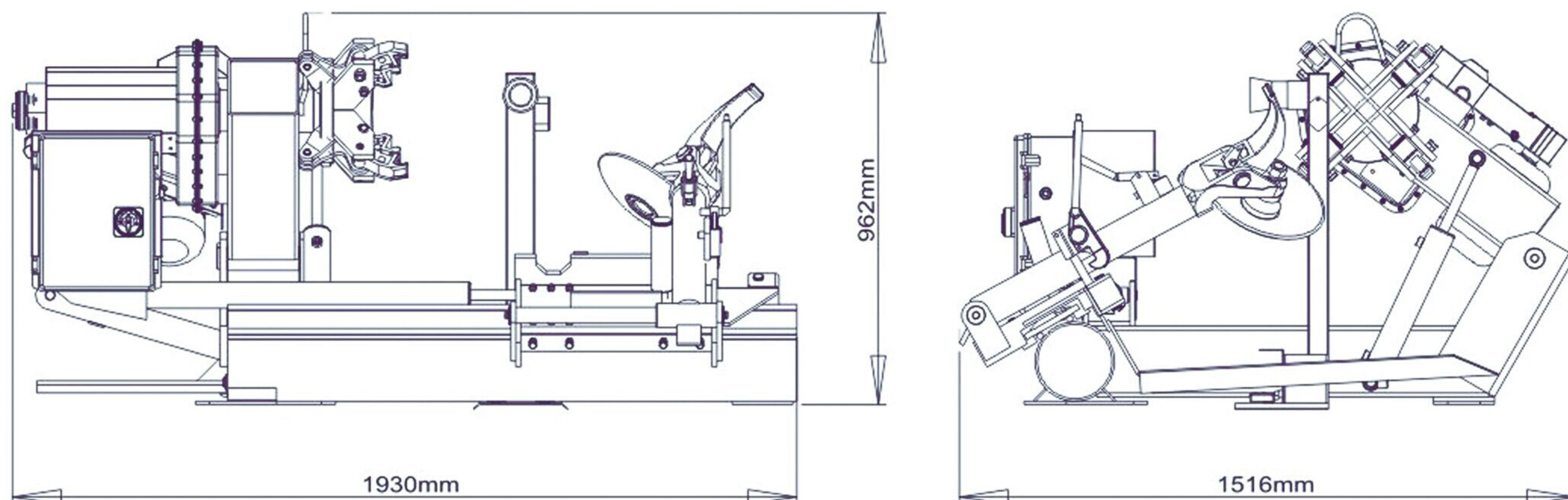

## ATC-1600 FEATURES

Application range: Applicable for changing tires whose rim diameter is between 14" –26" .

Product features: This tire changer can change various truck and bus tires.

Machine functions:

- 1、 Operating on control panel which is low–pressure and mobile,the control panel is designed light and handy.
- 2、 The operating pressure is 24v which is safe and reliable
- 3、 The assembly arm is equipped with pendular assembly round plate and assembly hook.
- 4、 The tool bracket, the lifting arm and the gripper are controlled by the hydraulic system.
- 5、 The clamping force adopts infinite regulation.
- 6、 The guide rail is welded integrally first, the processed; Such process avoids deformation caused by the weld and ensures the precision of the guide rail. The machine will move smoothly and steadily.

Machine quality: This product gained Europe CE certification.

## ATC-1600 SPECIFICATIONS

Rim diameter	14" –46"	Hydraulic motor	4.0hp
Max.tire weight	500kg	Max.Flow Of Oil For Hydraulic Motor	315
Max.wheel diameter	1600mm	Net Weight	1257LBS/(570Kg)
Max.wheel width	780mm	Gross Weight	1390LBS(630Kg)
Working pressure	≤130bar		2030×1570×940mm
Working voltage	415V/380V/240V/220V/110V	Loading Quantity	40"HCTNR 16pcs
Gear box motor	1.5KW		